

LUNCH

ISTRUZIONI DI MONTAGGIO ASSEMBLY INSTRUCTIONS

MODELLI
MODELS:

411/78.1105.22E Lunch per modulo mm 450 spalle: mm 15-20

Lunch for cabinet mm 450 sides: mm 15-20

411/78.1100.22E Lunch per modulo mm 600 spalle: mm 15-20

Lunch for cabinet mm 600 sides: mm 15-20

411/78.1110.22E Lunch per modulo mm 900 spalle: mm 15-20

Lunch for cabinet mm 900 sides: mm 15-20

411/78.1120.22E Lunch per modulo mm 1200 spalle: mm 15-20

Lunch for cabinet mm 1200 sides: mm 15-20

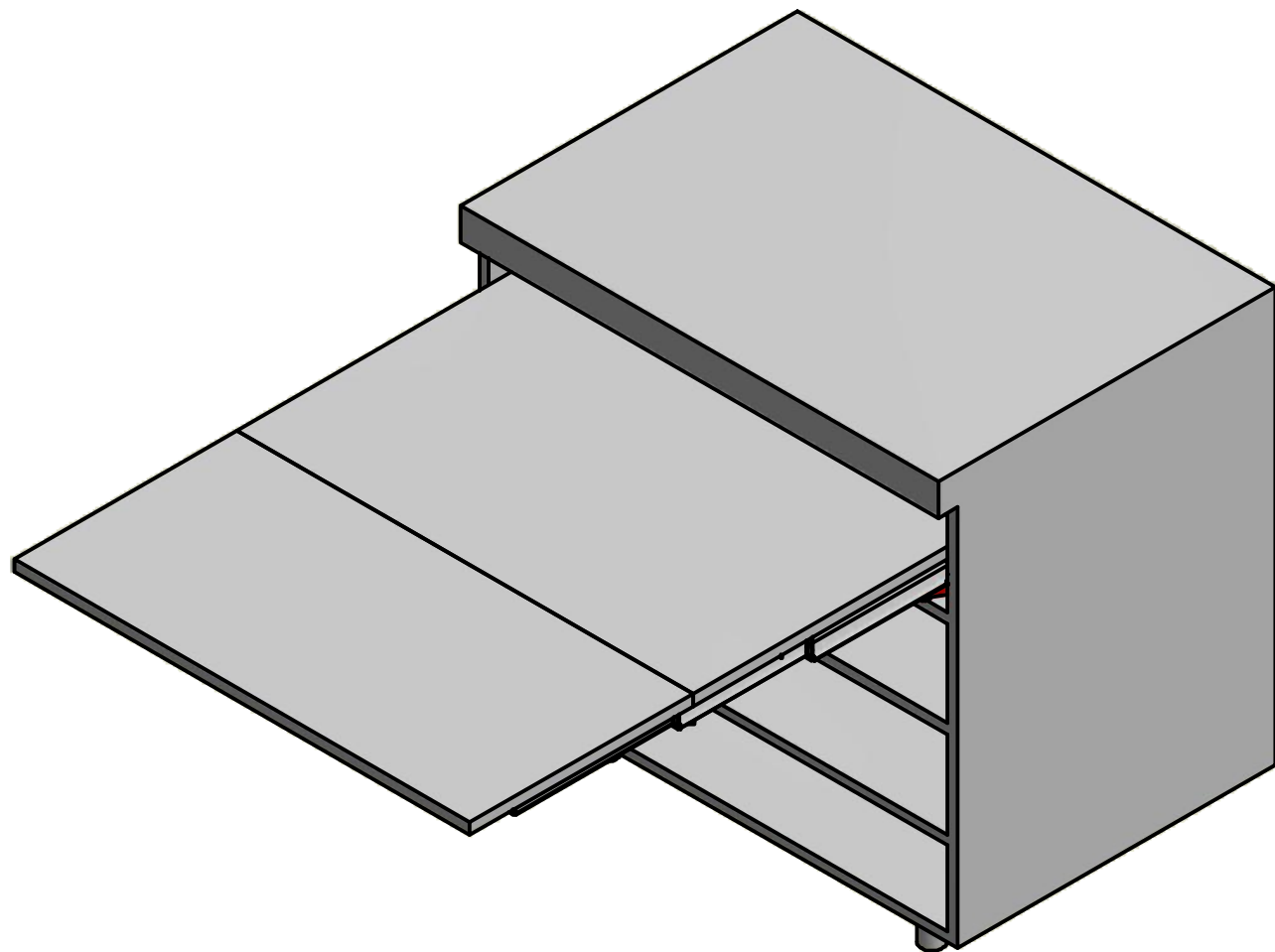

CONTENUTO DELLA CONFEZIONE INCLUDED IN THE PACKAGING

GUIDE PREASSEMBLATE
PRE ASSEMBLED SLIDES





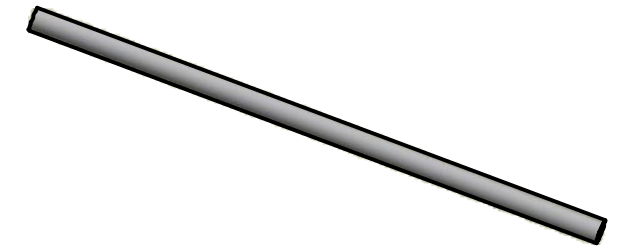

MANIGLIA
HANDLE



La lunghezza della maniglia dipende
dalla larghezza della base
Handle length depends on cabinet width

Maniglia mm 215/365/665/965
Handle mm 215/365/665/965

SACCHETTO ACCESSORI - ACCESSORIES

-  A. Vite TCCE M6x60 - *Socked head cap screw M6x60 (x 4)*
-  B. Vite TCCE M6x12 - *Socked head cap screws M6x12 (x 8)*
-  C. Bussola in ottone mm 12x8 M6 - *Brass bush 12x8 M6 (x 12)*
-  D. Chiave esa. da 5 - n° 5 *Allen key (x 1)*
-  E. Chiave esa. da 4 - n° 4 *Allen key (x 1)*

DIMENSIONI DI MASSIMA GENERAL DIMENSIONS

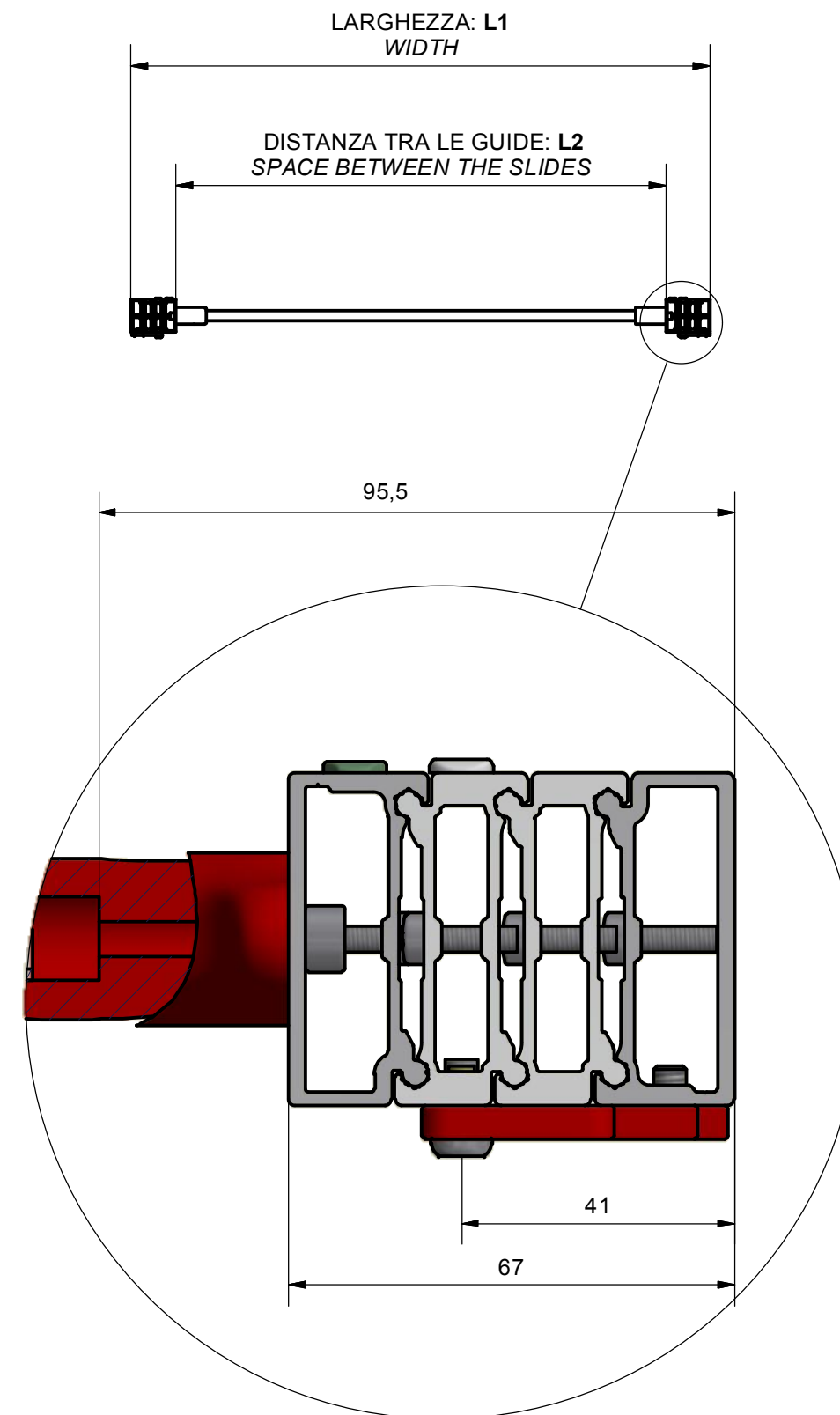
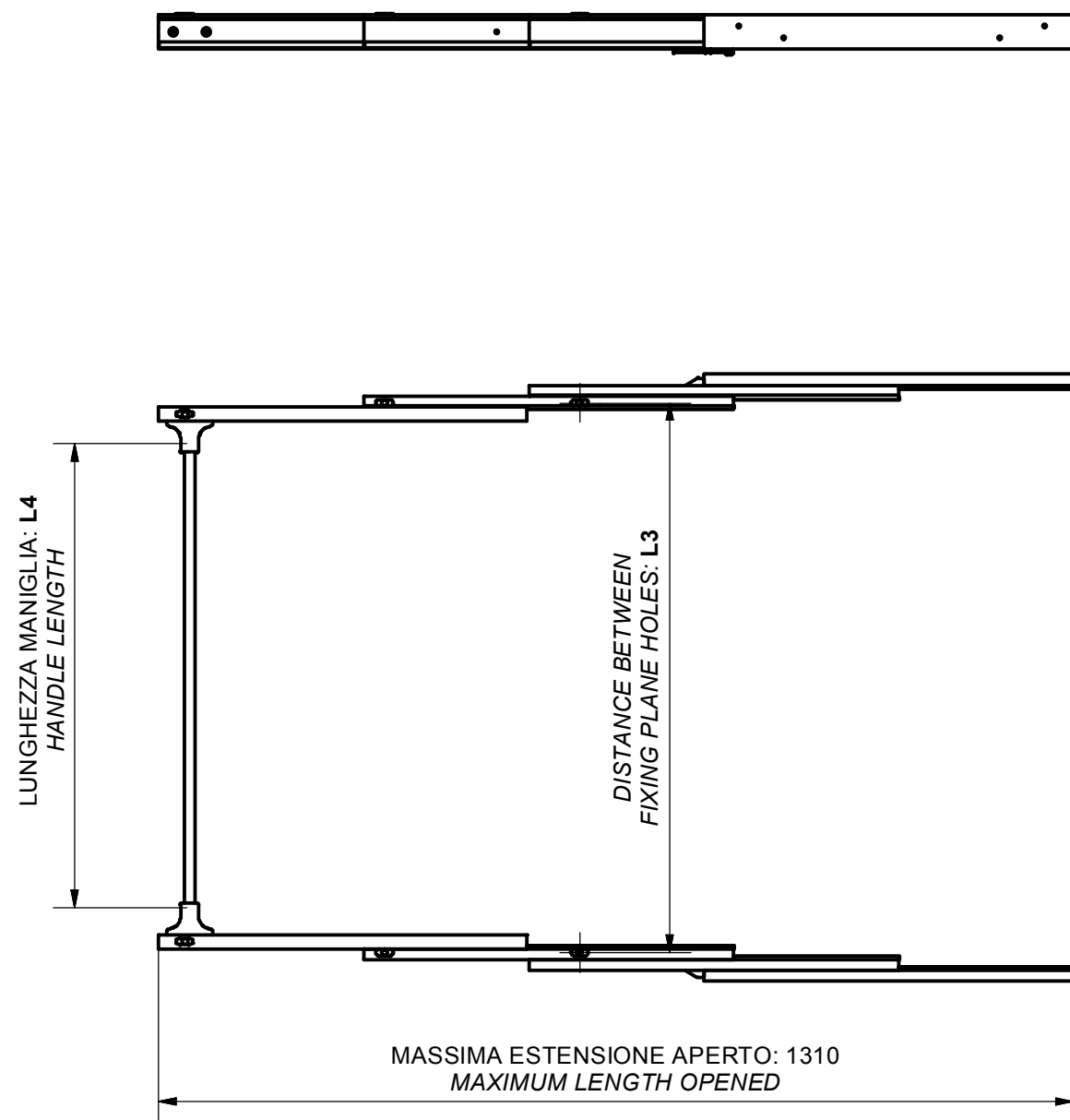

MODELLO - MODEL	MODULO - MODULE	L1 (mm)	L2 (mm) = L1-134	L3 (mm) = L1-82	L4 (mm)
411/78.1105.22E	450	410-420	276 - 286	328 - 338	215
411/78.1100.22E	600	560-570	426-436	478-488	365
411/78.1110.22E	900	860-870	726-736	778-788	665
411/78.1120.22E	1200	1160-1170	1026-1036	1078-1088	965

DIMENSIONI GENERALI MOBILE GENERAL CABINET DIMENSIONS

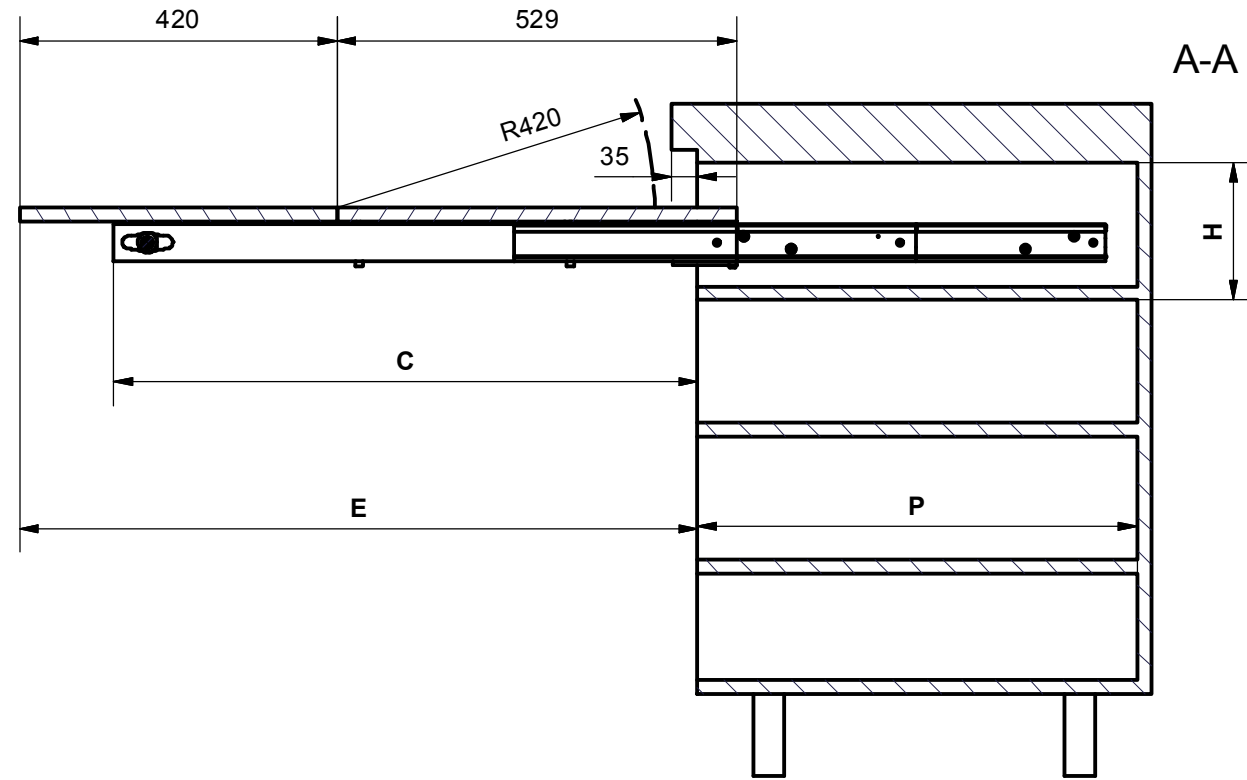

DIMENSIONE - DIMENSION	SIMBOLO - SYMBOL	
LUCE VERTICALE - VERTICAL FREE SPACE	H	MIN: 120 mm
PROFONDITA' INTERNA - INTERNAL FREE SPACE	P	MIN: 540 mm
LARGHEZZA INTERNA MODULO - CABINET INTERNAL WIDTH	L	MIN: 410 mm MAX: 1170 mm
SPESSORI PIANI E SPALLE - PLANE AND SIDE THICKNESS	S	15-20 mm
LARGHEZZA PIANI - PLANES WIDTH	Z	L - 5 mm
APERTURA MAX PIANI - MAX OPENING PLANES	E	895 mm
APERTURA MAX MECCANISMO - MAX OPENING MECHANISM	C	773 mm

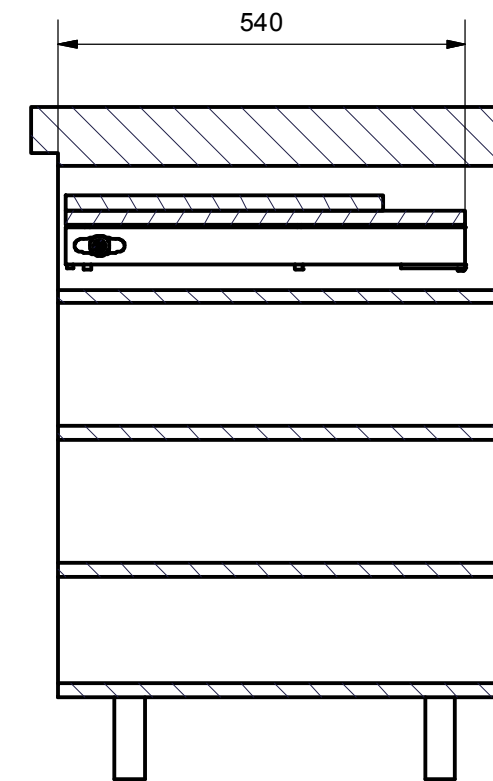
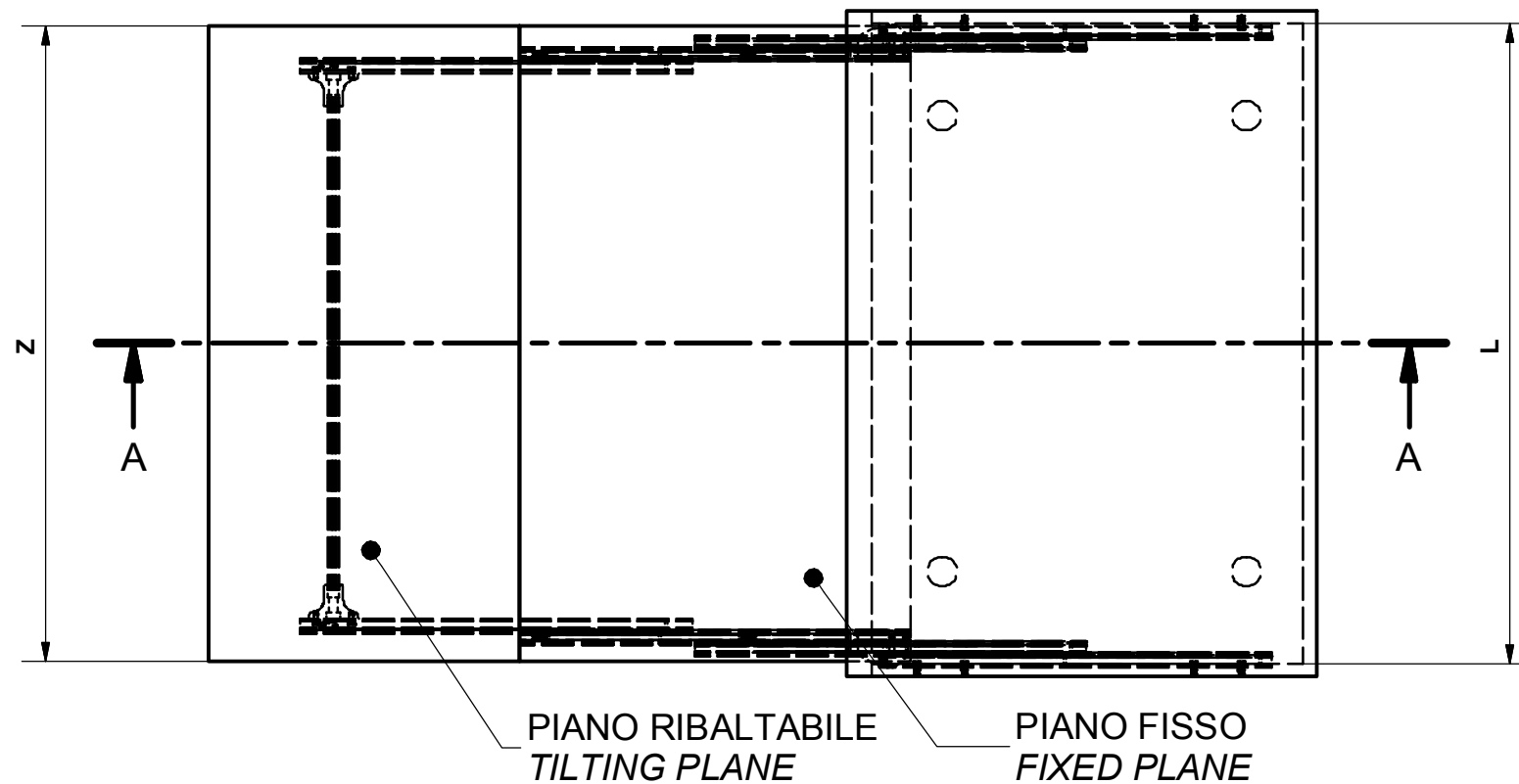

POSIZIONE FORI FISSAGGIO MECCANISMO

HOLES FOR MECHANISM POSITION



C. Bussola in ottone M6 mm 12x8 (x 8)
M6 mm 12x8 Brass bushes

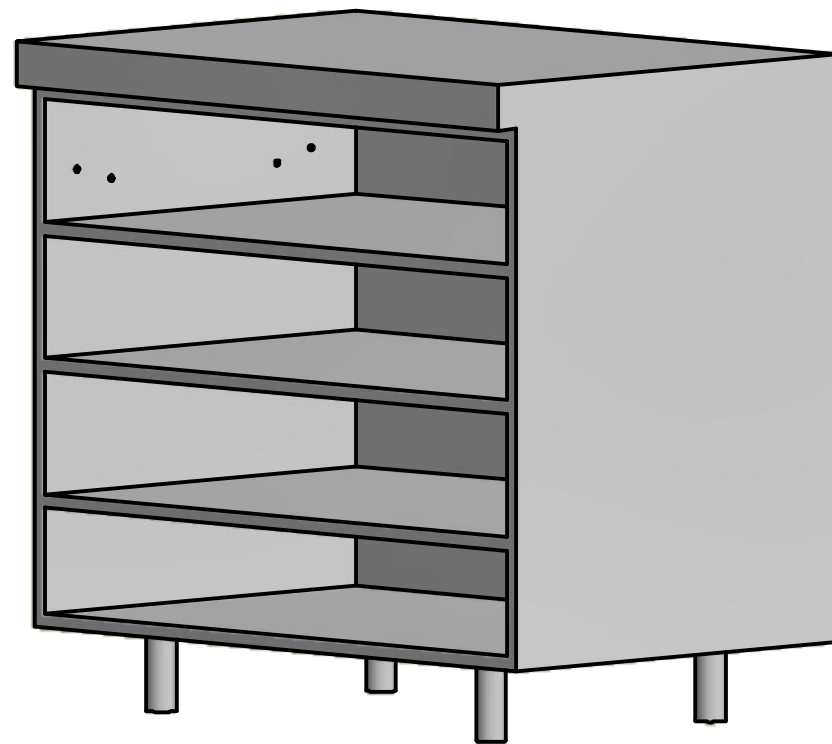

Ricavare su ciascuna spalla del mobile 4 fori $\text{Ø}8 \times 13$ per le bussole m6 incluse nella confezione la quota indicata di 50 mm, lascia uno spazio libero tra guida e pianetto sottostante di circa 25 mm

Drill on each cabinet side four $\text{Ø}8 \times 13$ holes for the included m6 brass bushes.

the indicated 50 mm dimension leaves a free space between the bottom of the slides and the plane of about 25 mm

* Per bilanciare la flessione del meccanismo, suggeriamo di eseguire le forature per il fissaggio guida con una differenza di 2-3 mm tra lato anteriore (quota 716 passa a 717.5) e posteriore (quota 716 passa a 714.5)

To compensate the mechanism flexibility, we suggest to drill the holes with a difference of 2-3 mm between the anterior holes (dimension 717.5 instead of 716) and the posterior ones (dimension 714.5 instead of 716)

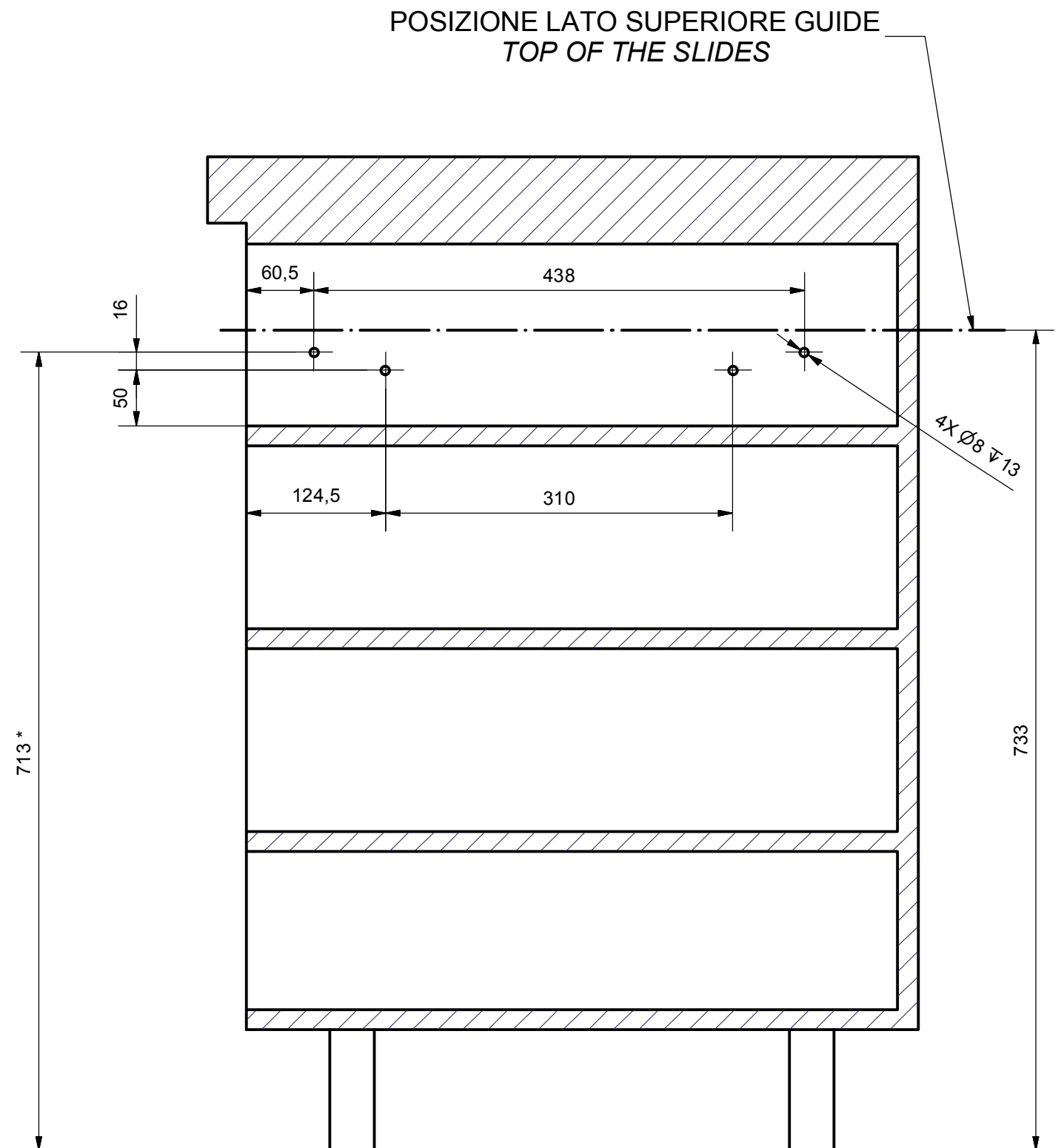

MONTAGGIO DEL MECCANISMO SUL MOBILE MOUNTING OF THE MECHANISM ON THE CABINET

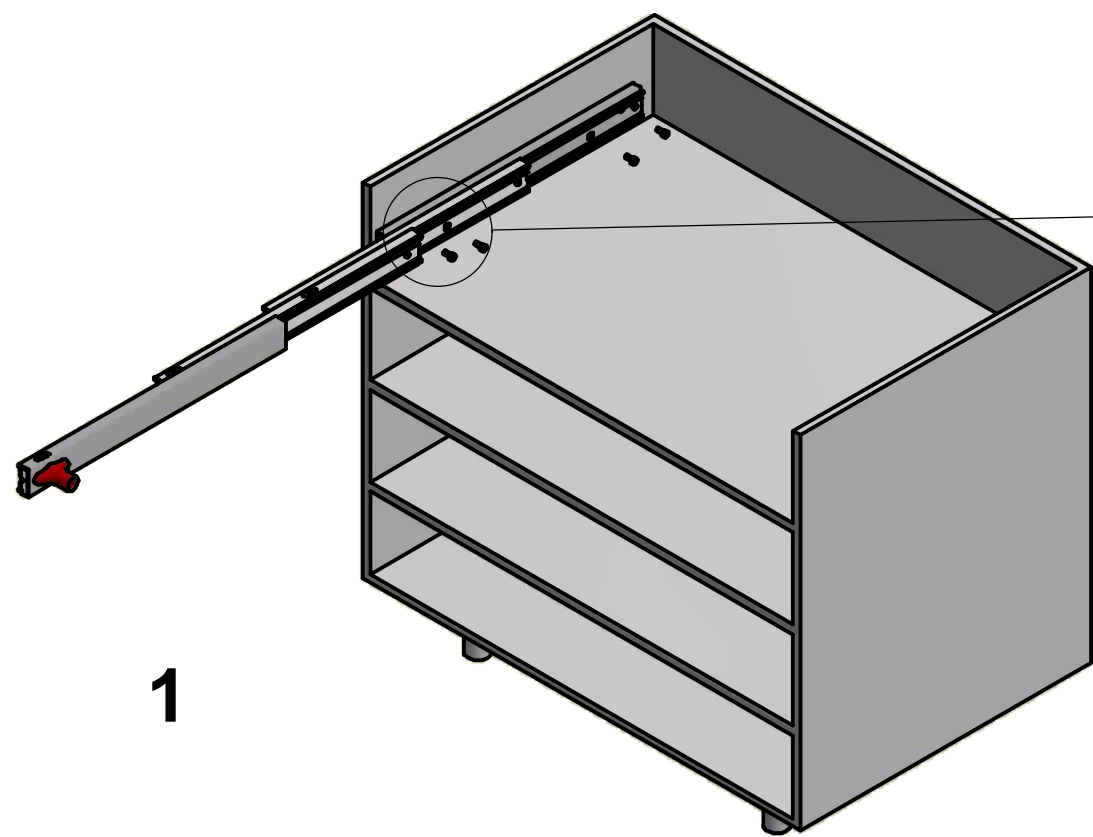

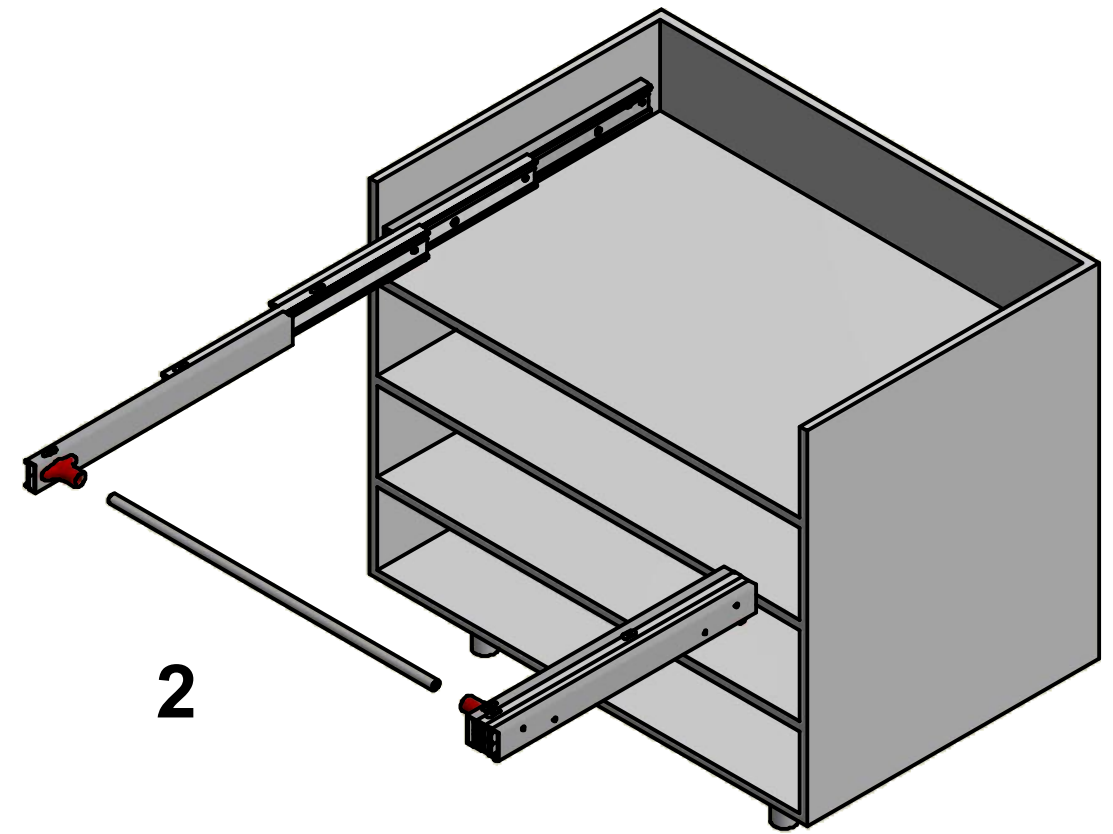

1

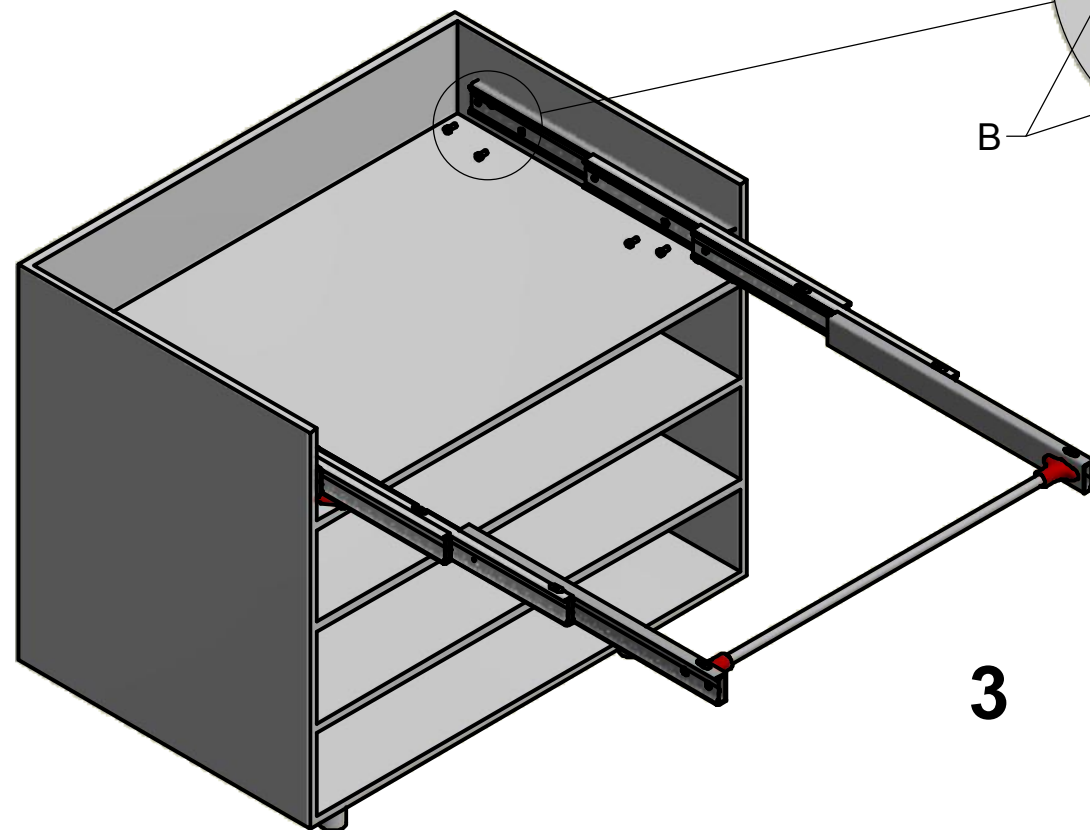

2



3

-  B. Vite TCCE M6x12 - *Socked head cap screws M6x12* (x 8)
-  D. Chiave esa. da 5 - n° 5 *Allen key* (x 1)

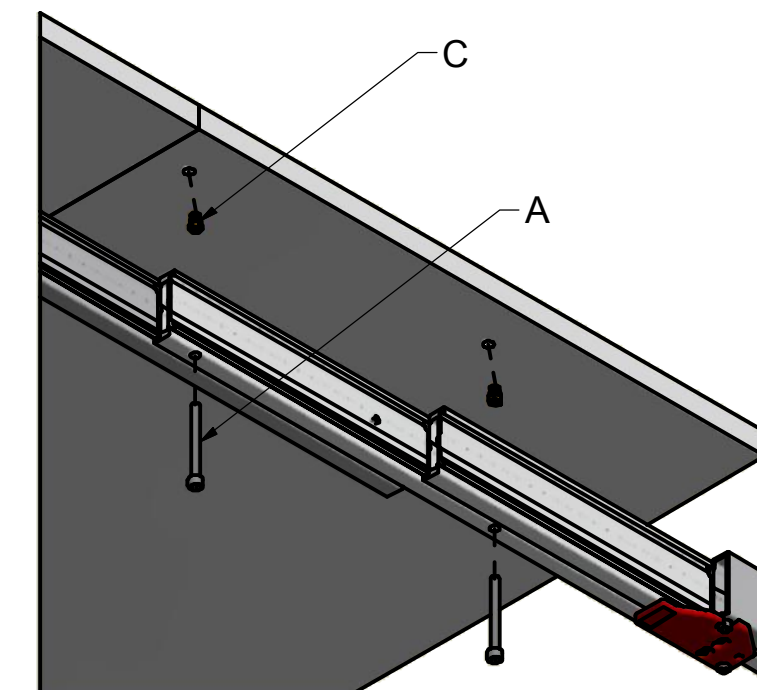
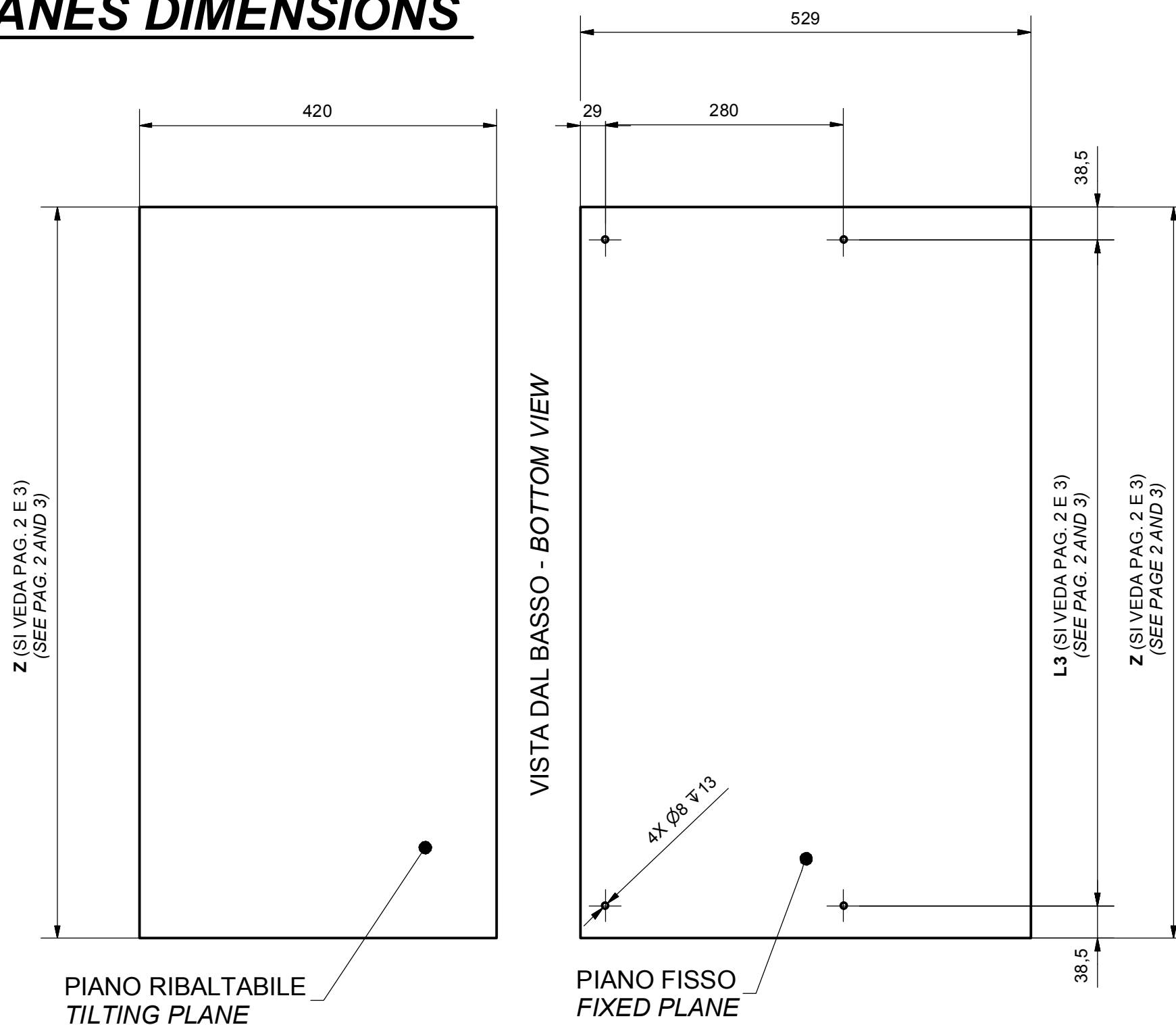

DIMENSIONI PIANETTI PLANES DIMENSIONS



Il piano fisso può essere montato utilizzando le quattro viti TCCE M6x60 (A) fornite a corredo inserite negli appositi fori sulle guide centrali.

The fixed plan can be mounted using the supplied four socked head screws M6x60 (A) inserted in proper holes on the central slides.

Realizzare sotto il piano fisso n. 4 fori $\varnothing 8 \times 13$ per le bussole M6 (C)
Drill under the fixed plane n. 4 $\varnothing 8 \times 13$ holes for M6 brass bushes (C)

-  A. Vite TCCE M6x60 - Socked head cap screw M6x60 (x 4)
-  C. Bussola in ottone mm 12x8 M6 - Brass bush 12x8 M6 (x 4)
-  D. Chiave esa. da 5 - n° 5 Allen key (x 1)

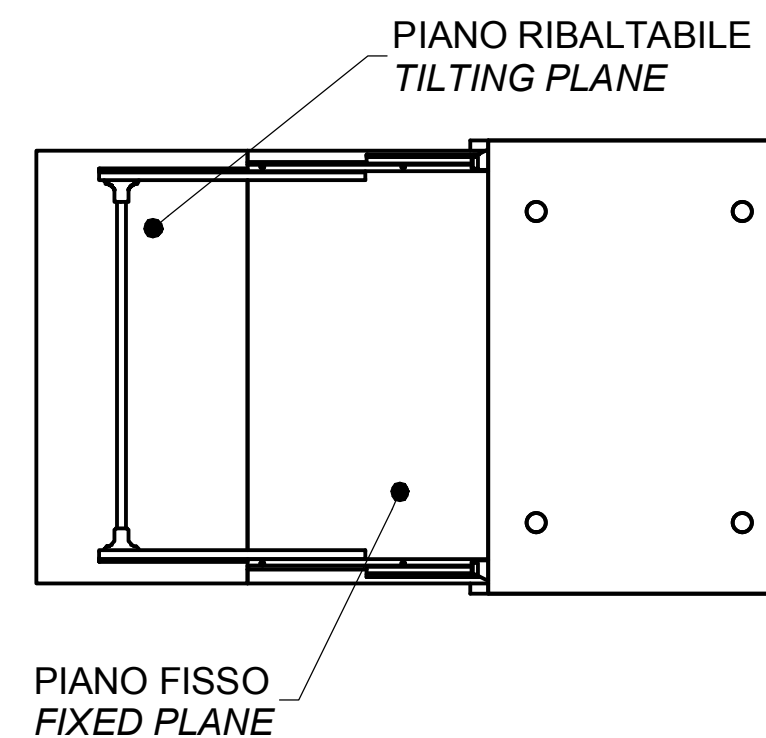

SEQUENZA DI FUNZIONAMENTO FUNCTIONING STEPS

CHIUSO
CLOSED

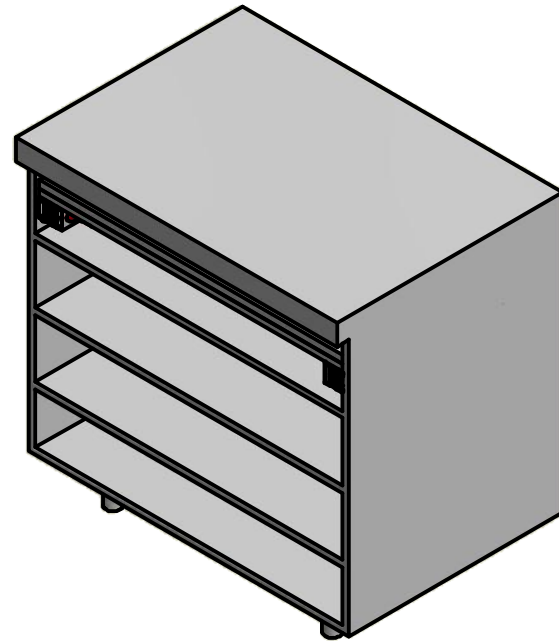

ESTRAZIONE GUIDE
SLIDES OPENING

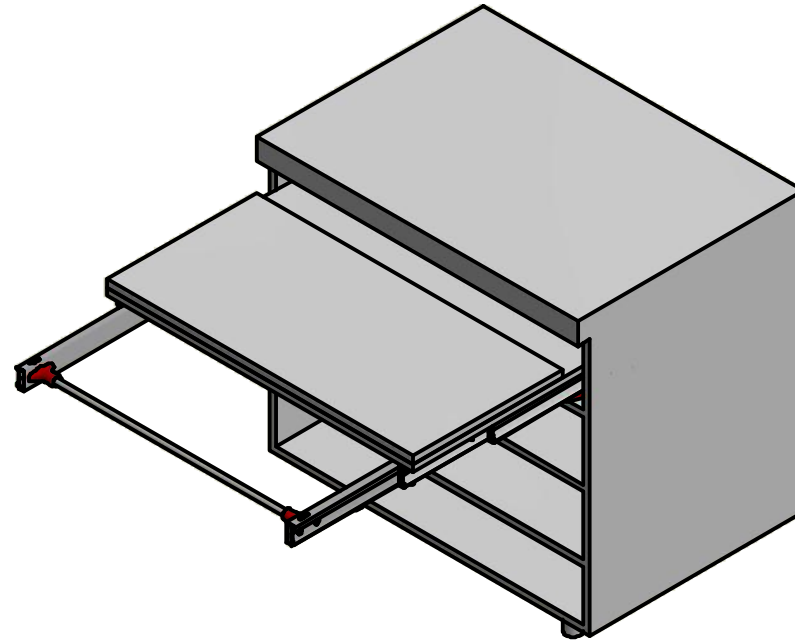

ROTAZIONE PIANETTO
PLANE TILTING

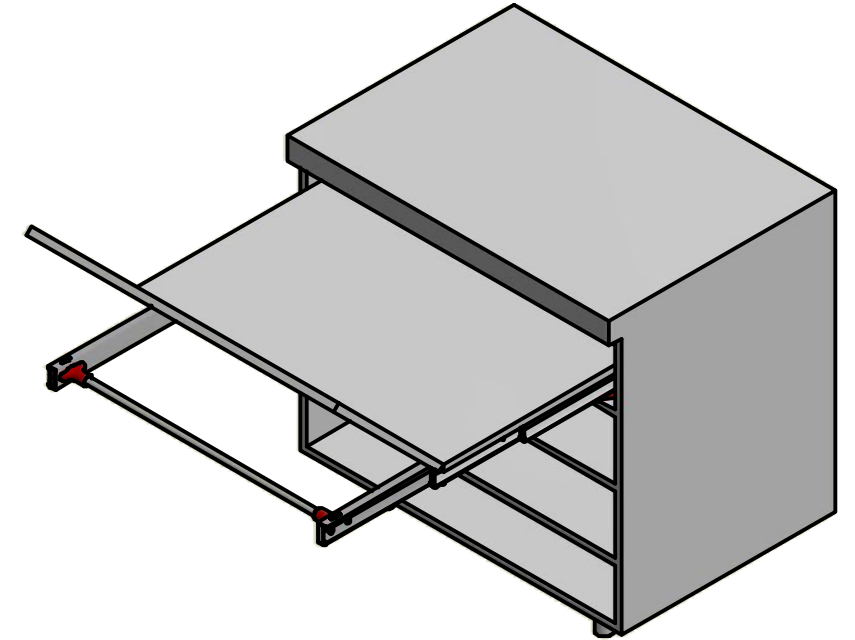

APERTO
OPENED

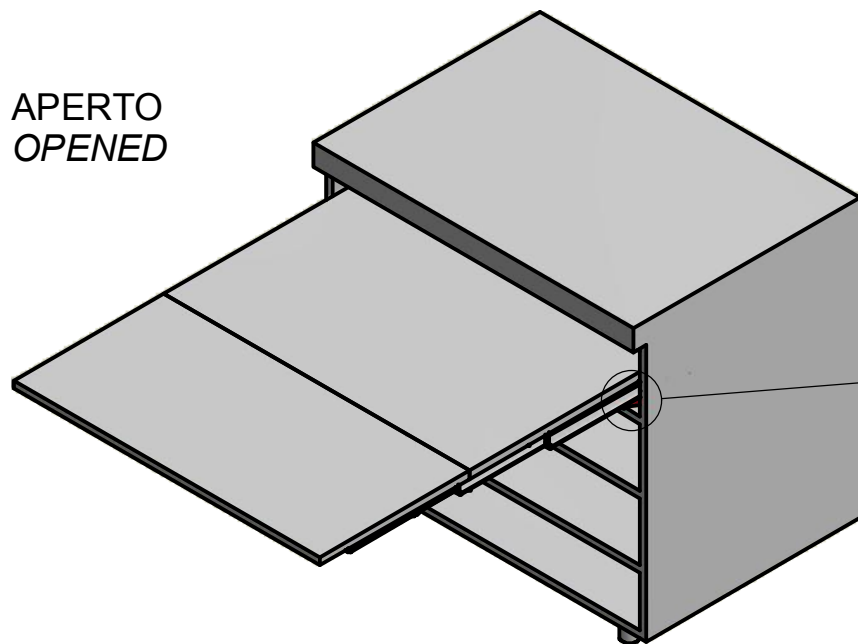

SPINGERE VERSO INTERNO LA LEVA
ROSSA PER CHIUDERE IL MECCANISMO
PUSH THE RED LEVER TO CLOSE THE MECHANISM

