

LAMP® Mono Flat Door Hardware FAD-20 for Medium-Weight Doors PAT.P Instruction Manual

Thank you very much for purchasing Mono Flat Door Hardware FAD-20.
Read this manual carefully beforehand for proper installation of this product.

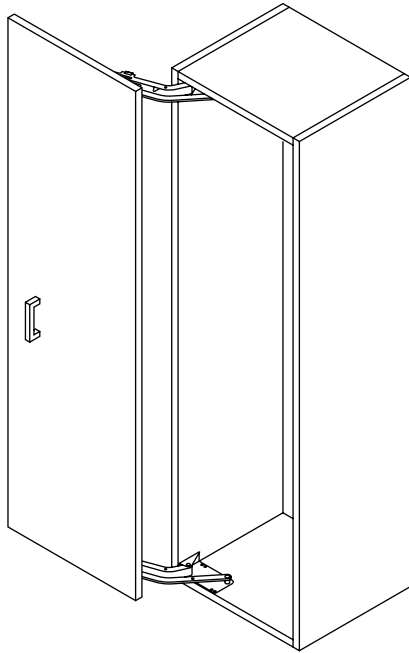







⚠ CAUTION

- Strictly follow the descriptions and notes in this manual. Improper installation may cause the door to fall off not only during installation but also during use, which may result in injury.
- Check the strength of the cabinet, and then secure each part of the product using screws that meet respective specifications.
- Do not use the product for doors with size or weight that does not meet the specifications.
- Do not disassemble or modify any part of the product.

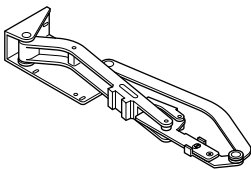
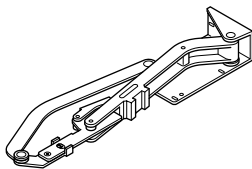
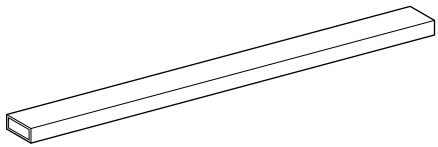
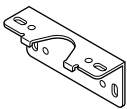
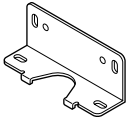
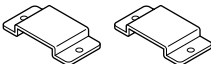
■ Specifications

Cabinet inner width	500 to 550 mm
Cabinet inner height	2420 mm max.
Door thickness	35 mm max.
Door weight	Max. 20 kg/door

■ Description of parts

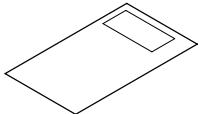
① Arm A 1 pc. 	② Arm B 1 pc. 	③ Connecting pipe 1 pc. 
④ Upper door bracket 1 pc. 	⑤ Lower door bracket 1 pc. 	⑥ Pipe clamp 2 pcs. 
⑦ Cap 2 pcs. 	⑧ Phillips head self-tapping screw 4.5X20 22 pcs. 	⑨ Phillips head screw M5X8 4 pcs. 
⑩ Hexagon socket head cap screw M4X8 4 pcs. 	⑪ Flat head Phillips self-tapping screw 4.5X20 2 pcs. 	⑫ Warning sticker 1 

Installation drawing (Unit : mm)

- These two drawings show an installation example for a left-side-opening type door. For a right-side-opening type door, the elevation view becomes rotationally symmetric and the plan view becomes bilaterally symmetric.
- The positions of the screw holes in the upper/lower door brackets are determined from the cabinet's inner edge as reference. When determining the screw hole positions from the door edge as reference, drill prepared holes taking overlaying allowance into consideration.
- This manual is described for left-side-opening type doors. For right-side-opening type doors, replace "arm A" and "arm B" in this manual with each other, and see figures left-right reversely.
- Tighten screws to the specified tightening torque even during assembly. Otherwise, they may become loose and fall off when the door panel is opened and closed several times.
- When some screws are loosened when the part mounting position is changed, be sure to tighten them again when the position is determined before opening/closing the door panel.

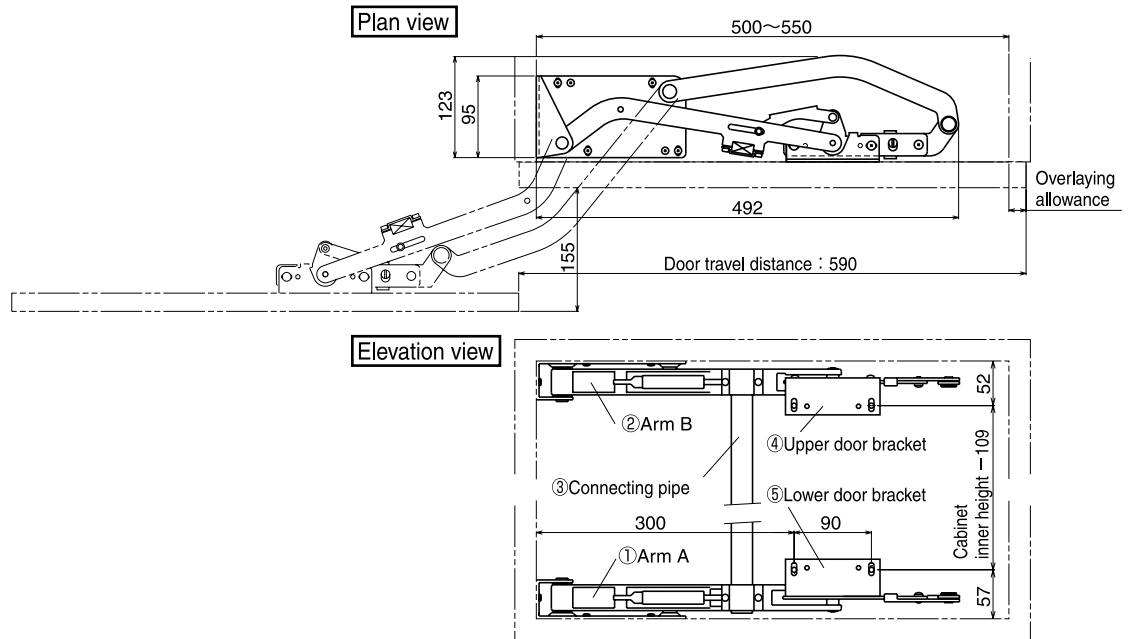

Installation procedure

1 Installing arm A to the bottom of the cabinet

- Check the door opening direction, and then secure arm A with five Phillips head self-tapping screws 4.5×20 (to the cabinet bottom panel through the four elliptical holes in the larger face and to the cabinet side panel through the one elliptical hole in the smaller face).
- Leave a 5-mm gap between the front end of the base bracket and the edge of the cabinet bottom panel. The arm A position can be fine-adjusted back and forth.
- Place arm A in close contact with the cabinet side panel to the left of the cabinet bottom panel.
- Secure arm A to the cabinet side panel with a Phillips head self-tapping screw 4.5×20 through the elliptical hole in the vertical face.
- Then secure arm A to the cabinet bottom panel with four Phillips head self-tapping screws 4.5×20 through the elliptical holes in the horizontal face.
- As the final step, secure arm A to the cabinet bottom panel with three Phillips head self-tapping screws 4.5×20 through the elliptical holes in the horizontal face. Do not use the elliptical hole marked with ✱ on the drawing.

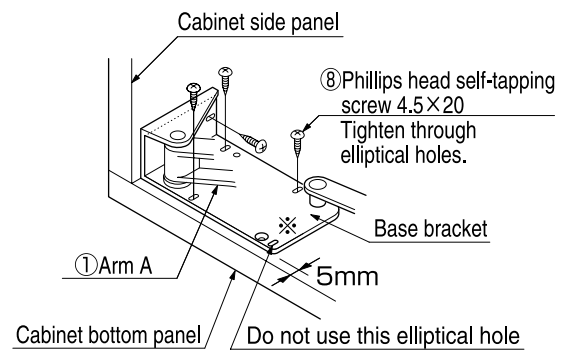

2 Installing arm B to the roof of the cabinet

- Secure arm B in the same way as arm A.

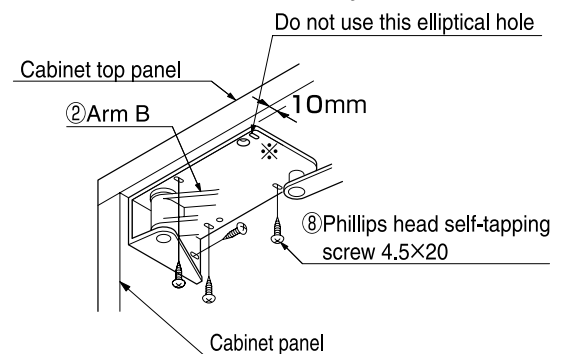

3 Installing the connecting pipe to the upper and lower arms

- Cut the connecting pipe to a length of (cabinet's inner height - 25) mm.
- Attach the caps to both ends of the pipe.
- Fit the connecting pipe with the recess of the upper and lower arms, and secure the pipe to the arms with the pipe clamps and hexagon socket head cap screws M4×8 as shown in the figure to prevent the pipe from coming off.

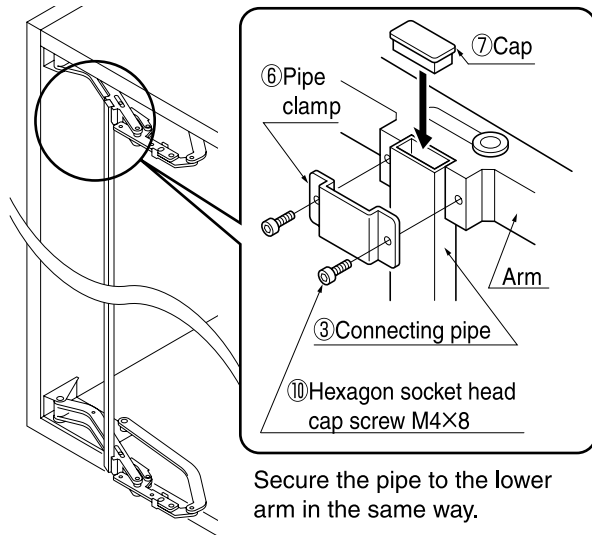

4 Installing the upper and lower door brackets to the door

- Secure the upper and lower door brackets with four Phillips head self-tapping screws 4.5×20 (two for each bracket) through the two elliptical holes in the larger face of each bracket. For the bracket mounting positions, see "Installation drawing" on page 2. The bracket mounting positions can be fine-adjusted vertically.

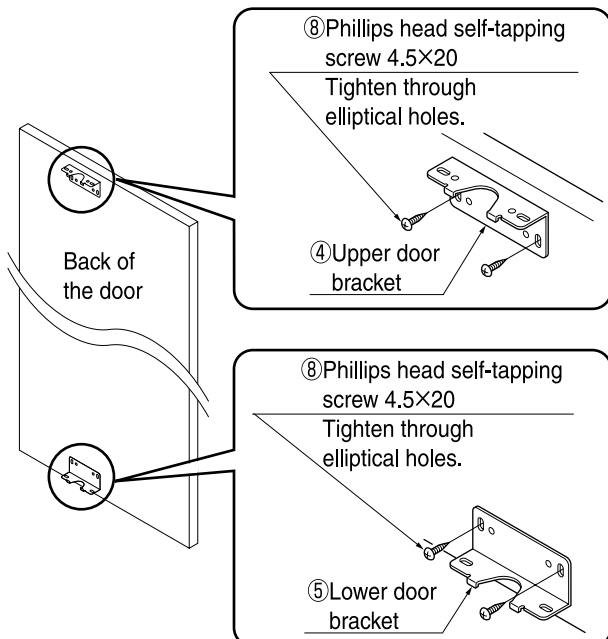

5 Installing the door to the upper and lower arms

- Insert the upper and lower door brackets into the joints near the connecting pipe, match the screw holes, and then secure the brackets and joints with Phillips head screws M5×8. The coupling positions can be fine-adjusted laterally.

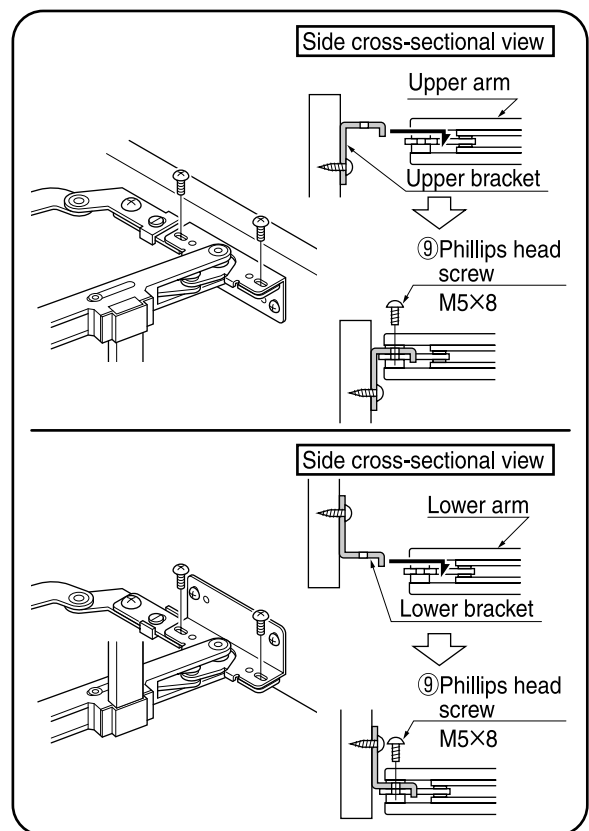
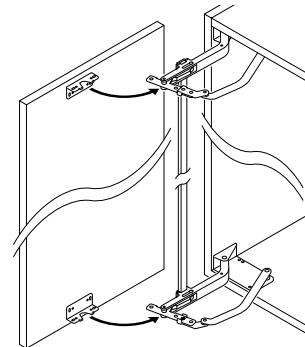

- If the screws cannot be tightened downward when securing the upper door bracket, they can be tightened upward from under the joint. In that case, be sure to use the screw holes (inside the elliptical holes) in the upper door bracket.

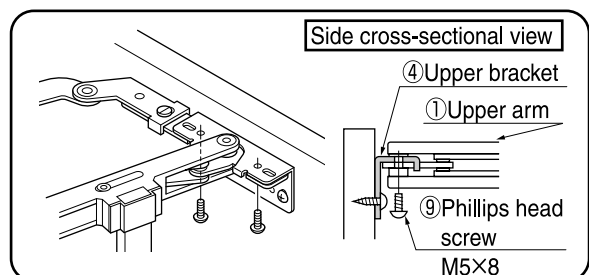

6 Adjusting part mounting positions

※ If a gap is generated above or under the door, fine-adjust the mounting position of the following parts with elliptical holes.

● Depth adjustment

- Fine-adjust the upper/lower arm mounting (to the cabinet) position back and forth.

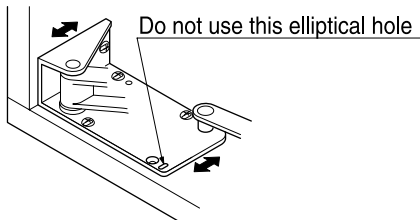

● Height adjustment

- Fine-adjust the upper/lower door bracket mounting (to the door) position vertically.

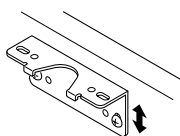

● Horizontal adjustment

- Fine-adjust the upper/lower door bracket mounting (to the arm) position laterally.

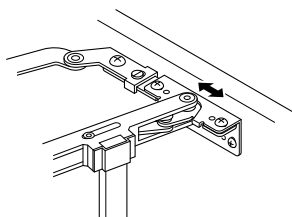

7 Adjusting the door mating face

※ If a gap is generated between the door panel and cabinet side panel at the left end or right end, adjust the door mating face using the following procedure to eliminate the gap.

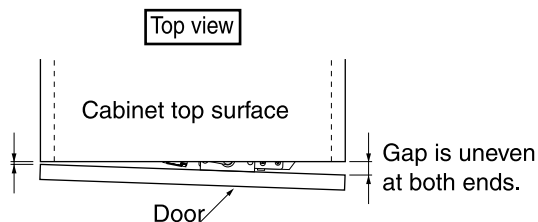

- Slightly loosen the Phillips head screw shown in the figure below (left) with a Phillips screwdriver.
- Turn the slotted-head pin shown in the figure below (right) with a flat-blade screwdriver.

Each turn of the slotted-head pin increases or decreases the gap between the door panel and cabinet side plate. (The slotted-head pin can be rotated endlessly.)

- When the gap has been eliminated after adjusting the door mating face, tighten the Phillips head screw with a Phillips screwdriver.

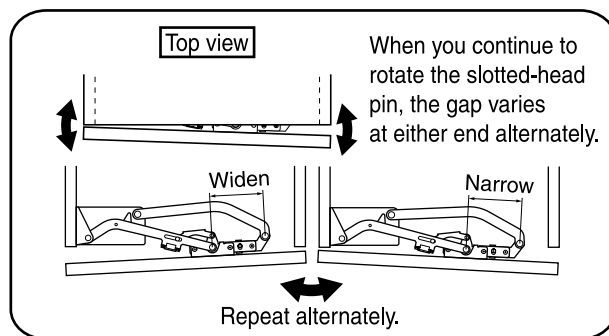
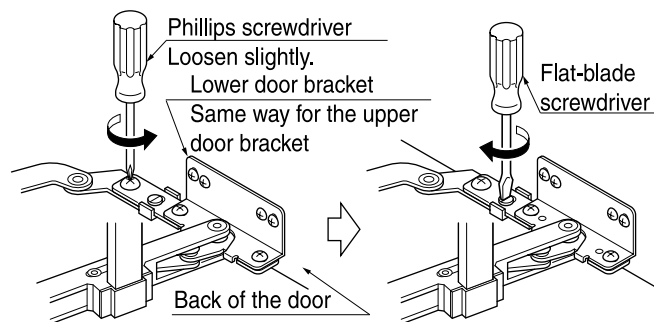

8 Tightening all other screws after adjustments

- Tighten the above-mentioned screws to the specified tightening torque.
- Secure the following parts with flat head and Pan head Phillips self-tapping screws 4.5×20 as shown on the drawings below. These screws will hold the different parts in place, so make sure to tighten them securely.

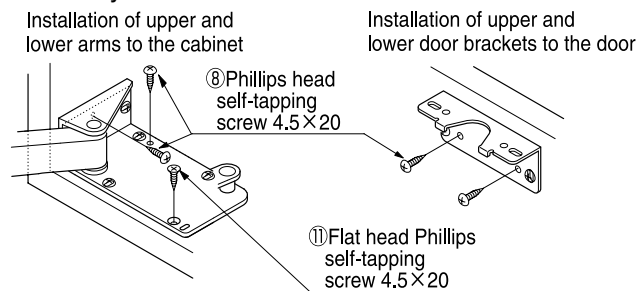

9 Installing a handle (not included) to the door

※ Be sure to install the handle to a location closer to the hinge than the center of the door.

SUGATSUNE KOGYO CO.,LTD.
 Phone: +81 3 3866 2260
 Fax: +81 3 3866 4447
 E-mail: export@sugatsune.co.jp
 Website: www.sugatsune-intl.com

SUGATSUNE KOGYO (UK) LTD.
 Phone: +44 118 9272 955
 Fax: +44 118 9272 871
 E-mail: sales@sugatsune.co.uk
 Website: www.sugatsune.co.uk

SUGATSUNE AMERICA, INC.
 Phone: +1 310 329 6373
 Fax: +1 310 329 0819
 E-mail: sales@sugatsune.com
 Website: www.sugatsune.com

SUGATSUNE SHANGHAI CO., LTD.
 Phone: +86 21 3632 1858
 Fax: +86 21 3632 1868
 E-mail: lamp@sugatsune.com.cn
 Website: www.sugatsune.com.cn